

## CONTENTS

The items listed below should be included in your package. If any items are missing, please contact us, prior to assembly, on 01905 25168.

Item	Description
1	Base
2	Rear Panel
3	Side Panel, RH
4	Lid, hinged
5	Shelf, upper
6	Shelf, lower
7	Side Panel, LH
8	Doors (x2)
9	Headphone Panels (x2)

Item	Description
A	Tube Nut, castor (16)
B	Castor (4)
C	Cup Washer, castor (4)
D	Bolt, castor (16)
E	Allen Key
F	Dowel (24)

### Also included

Screwdriver, posidriv

901 Controller Installation Kit, includes:-

4 machine screws, 4 spacers, 8 cable cleats

## ASSEMBLY

**Note:** For easier construction, threads have been cut into the dowel holes. This causes some unavoidable lifting of the veneer. Please be assured that following assembly these marks cannot be seen.

Two people may be required to assemble the trolley.

- 1 Fit the castors to the base panel (1). Begin by fitting the silver tube nuts (A) into base panel holes.

Four of the holes, along the back edge of the base panel, (shown right) have been countersunk, allowing the tube nuts to sit flush.

**Cup washers (C) are required for these four holes only.**

Hold the castor (B) in position, fit the cup washers (C) where necessary and bolts (D) using the Allen Key provided (E).

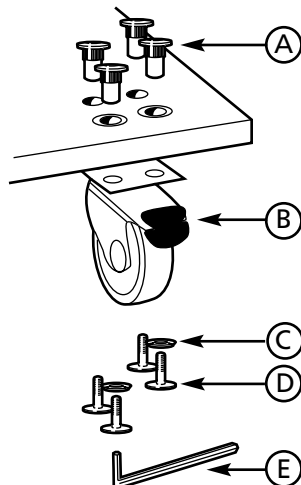

- 2 Using the screwdriver provided, screw dowels into base panel (1), both side panels (3 and 7) and the upper shelf (5). The dowels are marked in red on the illustration above.

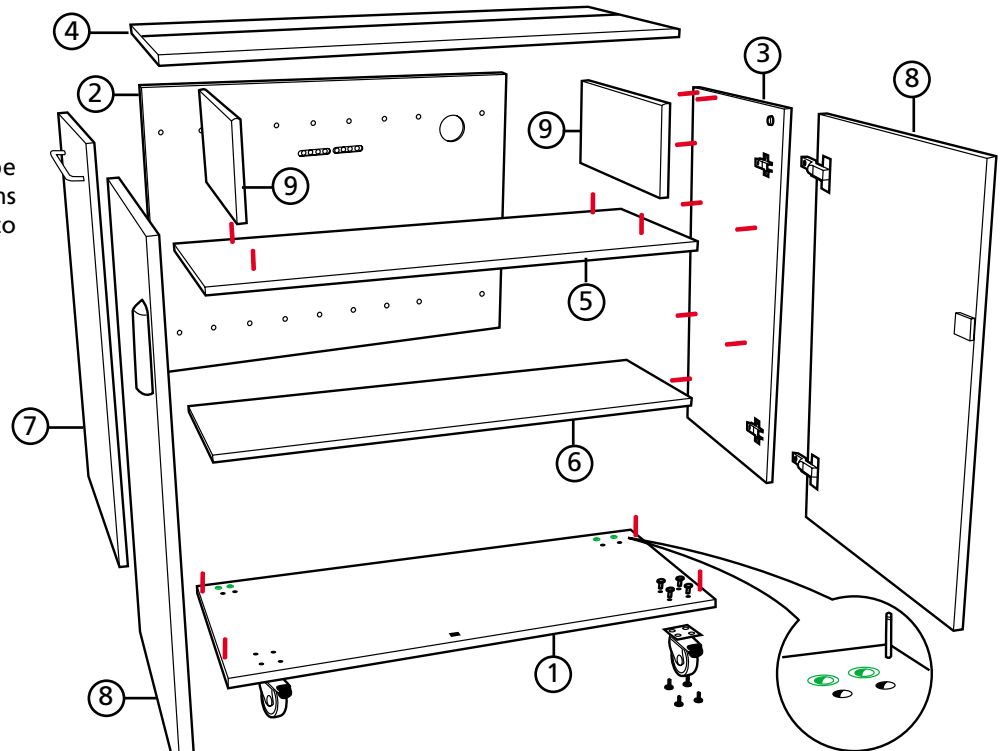

## CAM AND DOWEL CONSTRUCTION

With the exception of the wheels, the trolley is assembled using a dowel and cam system, requiring only a screwdriver.

Some wooden panels will have metal dowels (F). The abutting panels will have holes and cams.

Put two panels together, slotting the dowels into the holes and twisting the cams through 45° to lock them into position.

The cams must be in the unlocked position to allow fitment of the dowels.



- 3 Lay rear panel (2) on floor (with the winder hooks facing the floor) and fit the RH side panel only (3) into position, locating the dowels and locking them with the cams.

- 4 Fit hinged lid (4) into position and secure by locking dowels and cams. The hinged part of the lid can be locked into position if required by using the sliding bolt provided.

- 5 Fit the upper shelf (5), which is the larger of the two shelves, remembering to have the veneered edge facing the front.

Secure by locking the dowels and cams.

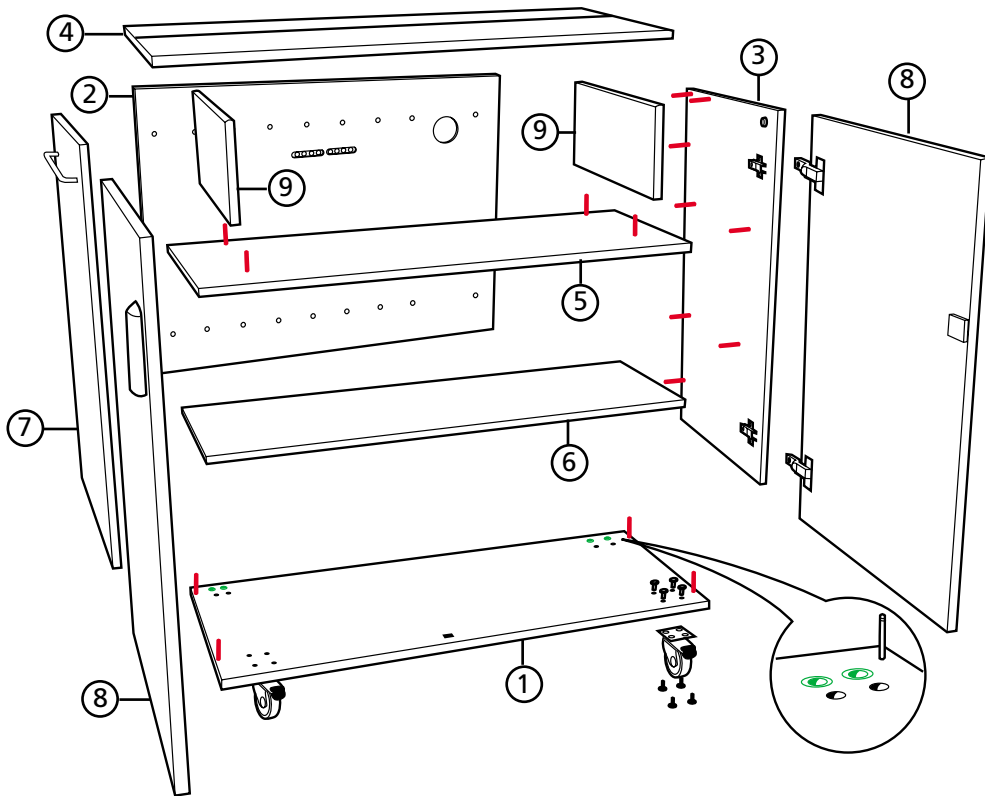

- 6 Fit the lower shelf (6) next, securing in the same way as the upper shelf.
- 7 Fit LH side panel (7) into position and lock all of the cams for the lid (4) and shelves (5 & 6).
- 8 Fit the base (1) into position, noting that castor bolts at the rear of the base sit flush in countersunk holes (marked in green on the illustration above).
- 9 With a helper, stand the assembly upright and lock the castors by depressing the black catches on each wheel.
- 10 The doors (8) can now be fitted. The helper may be required to steady the door and assist in locating the hinges correctly. *The handles should be towards the top of the doors.*

Slide the hinge plates together until the slot fits under the lock screw.

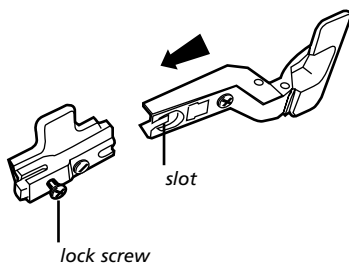

Tighten the lock screws lightly to secure the doors.

The fit of the doors may be adjusted using the adjuster screws (shown right).

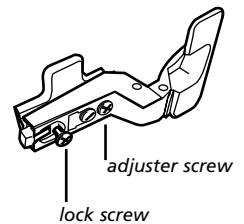

Once set, fully tighten the hinges using the lock screw.

- 11 Fit both headphone supports (9), ensuring that in both cases, the veneered edges face outwards.

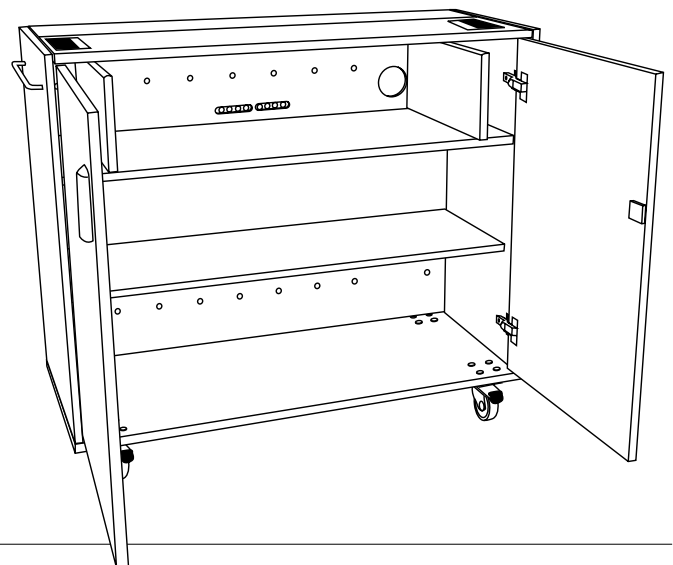

Tel: 01905 25168 Int. Tel. +44 1905 25168  
 Fax: 01905 612701 Int. Tel. +44 1905 612701  
 Email: sales@coomber.co.uk  
 Web: www.coomber.co.uk  
 We reserve the right to make changes deemed necessary without prior notification.

Coomber Electronic Equipment Ltd.  
 Croft Walk  
 Worcester  
 WR1 3NZ  
 U.K.