

Coomber

901 Operating Manual

Software version CCP230A



PORTABLE LANGUAGE LABORATORY

CONTENTS

INTRODUCTION _____	2	WORKING IN MODES _____	8
SETTING UP _____	3	Monitor Mode	8
The Coomber Language Learning System		Call Teacher	8
Coomber Connecting Cables		Intercom Mode	8
Bespoke Cables		Conference Mode	9
Using The Trolley		Copy Teacher Tape Mode	9
Connecting 3902, 3904 or 3907 Student Stations		Copy Line/Aux Mode	10
to the 901 Controller		Copy Microphone Mode	10
CONTROLS AND CONNECTIONS _____	4	Assessment Mode	11
OPERATING THE 901 CONTROLLER _____	5	Fast (x2) Copy Tape Mode	11
Starting Up	5	SAFETY AND GENERAL INFORMATION _____	12
Option Keys	5		
Mode Keys	5		
Volume Keys	6		
Internal & External Loudspeakers	6		
SELECTING MODES _____	7		
Mode Descriptions			

INTRODUCTION

The Coomber Language Laboratory provides a portable, inexpensive method for learning languages.

This system consists of the Coomber 901 Controller and up to eight Audio Active Comparative (AAC) or Audio Active (AA) student stations. The 901 controller provides the power necessary to operate all of the student stations and can control many of the student station functions.

An LCD (display) built into the 901 controller describes each mode and allows control of up to 8 x 3902, 3904, 3907 student stations enabling the teacher to record, playback, pause, rewind and stop those stations connected. The 901 controller can identify, monitor and communicate with each station or communicate with the entire group.

Audio Active

Audio Active recorders operate in the same way as domestic cassette tape recorders. A recording takes up one half of the cassette tape. Turn the tape over, and recording can continue using the other half of the tape.

Audio Active Comparative

Unlike a domestic cassette tape recorder, Audio Active Comparative (AAC) recorders, use both halves (or tracks) of the tape during recording; in this case, recording the teacher on one track and the student on the other. It is ideally suited for assessment purposes, since the teacher questions cannot be erased by the student.

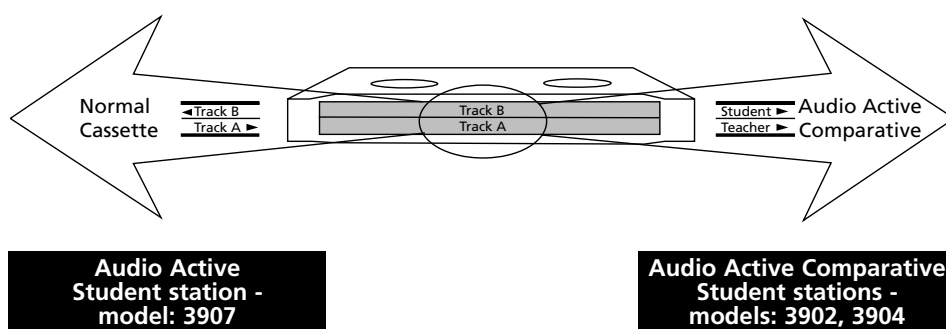

UPDATE INFORMATION

Software Version CCP227

901 controllers manufactured before the 17th June 1998 (preceding S/W CCP227), record the students voice on the **student** track in **all** modes. 901 controllers manufactured after 17th June 1998 (exceeding S/W CCP227), will record the students voice on the **teacher** track whilst in **assessment mode**. This change now allows the cassette to be used on a conventional cassette recorder for assessment appraisal.

Software Version CCP230

Conference Mode displays have been altered to conform with similar instructions in other modes. In all cases, Key A is for CANCEL, key B is for ALL.

WHICH SOFTWARE?

To find out which software version you have simply switch on the 901 controller and hold down Key A or B. The software version (S/W) and release date will now be displayed.

SETTING UP

The Coomber Language Learning System

Due to its adaptability, the Coomber Language Learning System can be used as a "fixed installation", be moved and used anywhere in any classroom, or be easily transported on a trolley.

Coomber Connecting Cables

If the language learning system is to be "fixed" in one position, pre-made cables of different lengths are available to make installation easier. The cables lengths available from Coomber are as follows:-

Order code	Cable Length	Cable Type
1948	0.5m	plug to plug
1949	1.5m	plug to plug
1950	5.0m	plug to plug
1947	5.0m	plug to socket (extension)

Bespoke Cables

Suitable technicians should be able to manufacture bespoke cables to suit your needs if required. In this case, please read the following notes.

1. Cable Type

7 core with inner and outer screen. (Our part no. JD 1)

Note: Coomber connecting cable has been selected to provide optimum performance during use. Alternative specification cables may cause detrimental performance of the language laboratory system for which we cannot be responsible.

2. Connection

Connect JD 1 cable to 8 pin DIN plug as shown below.

8 pin DIN plug connections

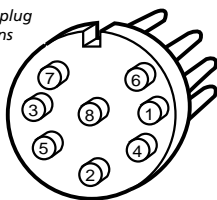

1. Brown
2. Inner Screen
3. Orange
4. Yellow
5. Green
6. Blue
7. Violet
8. Grey Skirt - Outer Screen

3. Plug Type

8 Pin DIN (RS Components No: 473-256)

4. Warning!

Ensure that there is no connection between inner and outer screens.

Also ensure cables are tested for shorts between any pins and pins to skirt, prior to connection, as permanent damage may result to equipment should a short circuit occur.

It is very important to adhere to the recommended specification cable type. Failure in complying, could result in poor immunity to interference and damage.

Note: We are unable to take responsibility for damage caused to equipment due to the use of incorrect or faulty bespoke cables.

Using the Trolley

A trolley (part no. 1966) is available for security, easy transportation and use.



Fitting the 901 Controller in the Trolley

The Controller can be secured and operated from the trolley. An installation kit, including 4 screws, 4 spacers and 8 cable cleats are included with the trolley.

1. Open trolley doors (as shown above) and feed the connecting cables through holes (one cable per hole). Fit the cable cleats over the cables and push the cleats into the holes to secure the cable.

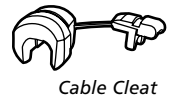

Note: The cable cleats will not provide a total restraint for cables should they be tugged at during use. Always take care to avoid accidents by ensuring that cables do not cause a hazard.

3. Connect each cable to the back of the 901 controller in numerical order.

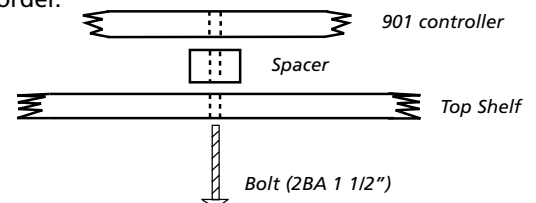

4. To secure 901 controller in position on the top shelf, position each spacer over a hole. Fit the two rear bolts loosely (two or three turns only) and lift the front of the controller to help locate the front two bolts.

Note: It is important that the four spacers are in position. Over-tightening the bolts may deform the controller.

5. Tighten all four bolts, do not over-tighten.

Connecting 3902, 3904 or 3907 Student Stations to the 901 Controller

1. Eight "8 pin DIN" sockets are located on the rear panel of the 901 controller. Each numbered socket is for use with one student station.

2. Connect cable to the right hand side of each student station as identified below.

- It is essential that the correct cable is used to connect the 3902, 3904 or 3907 student stations (Maximum eight).

- If using cable extensions, ensure adhesive tape is applied around the joint to prevent accidental separation.

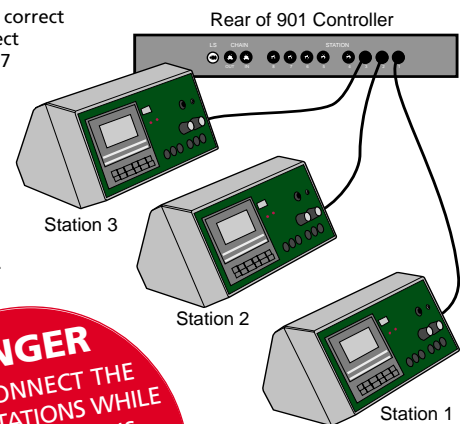

DANGER
NEVER CONNECT THE STUDENT STATIONS WHILE THE CONTROLLER IS SWITCHED ON. SERIOUS DAMAGE TO THE CONTROLLER COULD OTHERWISE OCCUR

CONTROLS AND CONNECTIONS

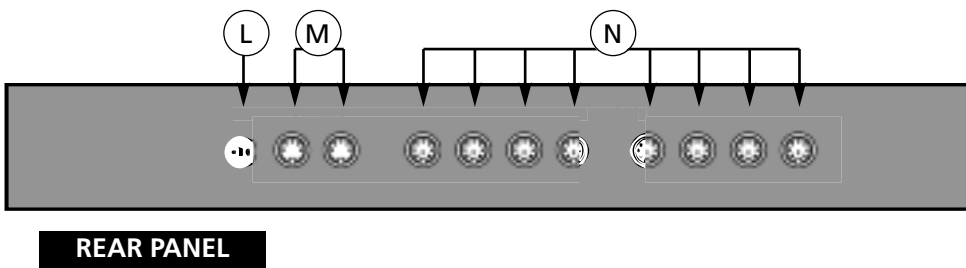
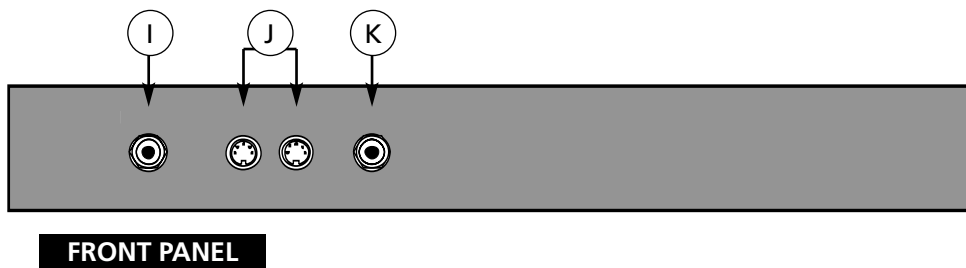
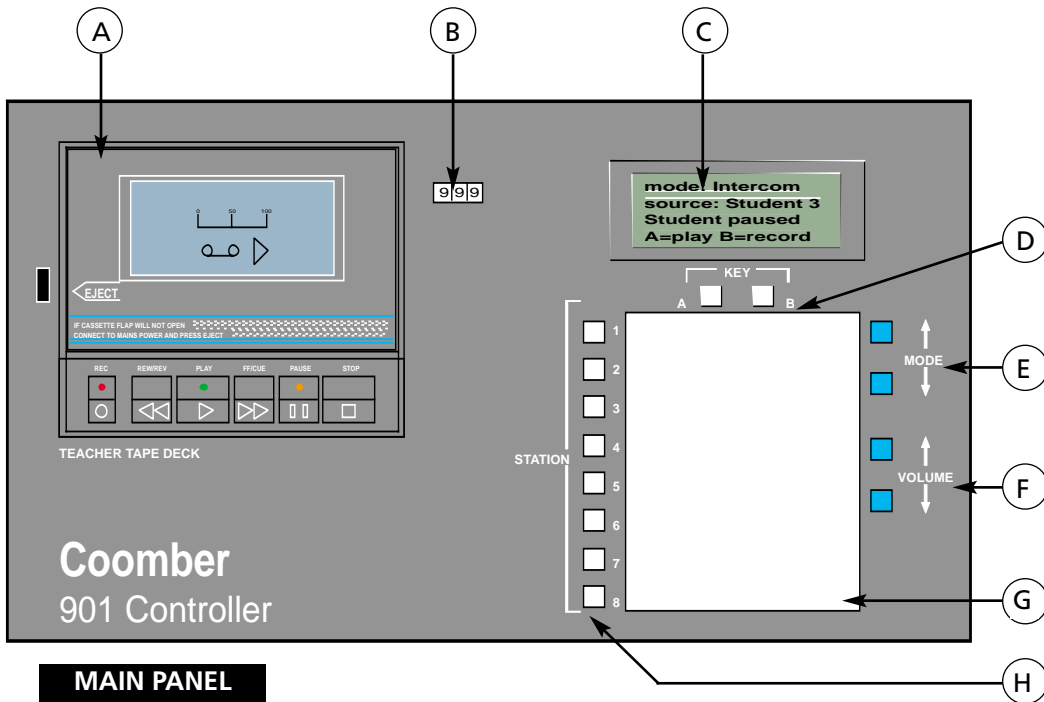

Key to Coomber 901 Controller

- A** Cassette deck
Solenoid controlled electronic deck in common with all 3902, 3904 and 3907 student stations
- B** Tape counter
- C** LCD (Display)
Views mode selected and student stations
- D** Option selection Keys
Allows selection of choices presented in different modes
- E** Mode selection Keys
Used to select different modes from menu
- F** Volume control Keys
- G** Memo pad
Wipe clean pad ideal for use with dry wipe marker pens
- H** Station select Keys
Offers interactivity with individual stations in some modes
- I** External Microphone
- J** Teacher Headset(s)
- K** Line Input
Input from external source such as cassette/CD/record
- L** Loudspeaker
The 901 is fitted with a loudspeaker. If required, the 901 will power an external loudspeaker in conjunction with the internal one, or (if the plug is fitted in reverse) operate on its own.

The external speaker must be not less than 4 ohms.
- M** Chain Connections
Allows the connection of the controller to a second controller.
- N** Student Station Connections
Connection point between the 901 controller and individual student stations.

OPERATING THE 901 CONTROLLER

Starting Up

1. Connect the student stations to the 901 controller as described on page 4.
2. Connect a headset to either of the two sockets marked 'headset' on the front of the controller.
3. Connect the 901 controller to the mains and switch on, using the switch on the right hand side of the 901 controller.

Note:

Please ensure that you have read the operating instructions for the appropriate student stations before proceeding.



This message will appear on the LCD:-

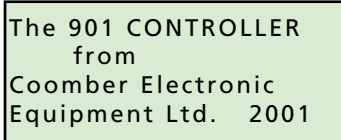

TIP!

Press Key A or B to display the operating system version whilst the start up message is displayed. Press MODE or VOLUME buttons for a short cut to MONITOR mode.

4. After approx. 5 secs, the start up mode will be displayed (MONITOR mode).

This message will appear on the LCD:-

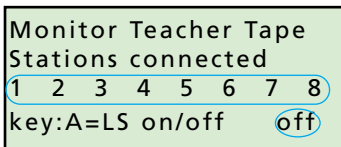

Identifies those student stations connected to the 901 controller

Indicates whether the loudspeaker is switched on or off

Option Keys

Often, the LCD monitor will display a prompt message, allowing the user to select or deselect an option such as that described on page 5 (Volume Control, item b), or as shown below by using the option Keys (D).

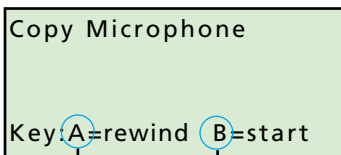

The prompt appearing on the LCD monitor allows the teacher to rewind all of student station tapes by pressing key A.

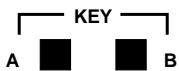

Pressing key B will simultaneously record on to all student stations via the teacher microphone.

Mode Keys

Use the Mode Keys (E) to scroll up and down through the different operating modes.

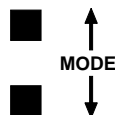

The operating modes are described over the next few pages.

Volume Keys

Use the up / down Volume Keys (F) to increase or decrease volume respectively.

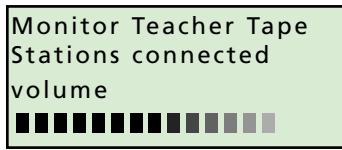
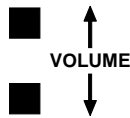

The moment the volume keys are depressed, the display will change to show the volume (as a bar) and whether it is being increased or decreased.

Internal & External Loudspeakers

The Controller is fitted with an internal Loudspeaker. It also has a socket on the rear allowing an external loudspeaker (not less than 4 Ω) to be connected. This socket is reversible, so that depending how the plug is fitted, the external loudspeaker can be used by itself or in conjunction with the internal loudspeaker.

Listening using internal or external loudspeakers

- Ensure you are in MONITOR mode.
- Press key 'A' (immediately below the LCD) to turn the loudspeaker on.

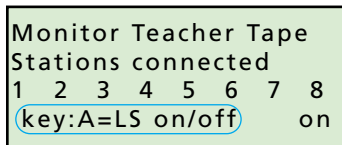

The LCD displays a choice. Key A will switch the loudspeaker on or off.

- Insert a pre-recorded cassette into the teacher cassette deck on the controller.
- Press play on the teacher cassette deck.
- Adjust 'Volume' to suit.

In this instance the loudspeaker is switched on!

INFORMATION

Teacher headset(s) can be adjusted in any mode. Loudspeaker volume can only be adjusted at certain times. See the chart below for information.

Notes:

- The cassette in the controller can only be heard through the internal / external loudspeaker in 'MONITOR TEACHER TAPE' or 'COPY TEACHER TAPE' (once copying has begun).
- Only in MONITOR mode can you toggle the internal / external loudspeaker on or off by pressing 'key A'.
- Though switched on, the loudspeaker will only be active in the modes shown in the chart below.

MODE	LOUDSPEAKER ACTIVE	LOUDSPEAKER VOLUME ADJUST
MONITOR Teacher Tape / Station*	YES	in monitor teacher tape only
INTERCOM	NO	NO
CONFERENCE	NO	NO
COPY TEACHER TAPE	YES (when copying)	when monitoring teacher tape only
COPY LINE / AUX	YES (when copying)	when monitoring source only
COPY MICROPHONE	NO	NO
ASSESSMENT	NO	NO
FAST (x2) COPY TAPE	NO	NO

* loudspeaker plays sound only from the teacher tape, not from the student station if selected - though at the same time, the headset will switch from listening to the teacher tape to the student station.

SELECTING MODES

The MODE Keys (E) allow the user to select different modes in which to work.

Two keys are provided so that the user may scroll up or down the list of alternative modes, but essentially the list is cyclic by nature (as shown right).

By pressing either mode key, the different modes appear in the LCD screen, starting in MONITOR MODE and scrolling all the way through the list until MONITOR MODE is reached again.

One key works up through the list, the other works down!

Note: The Controller always starts up in MONITOR MODE.

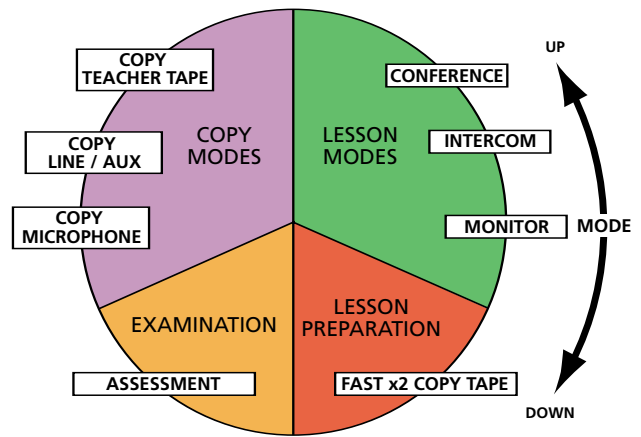

Mode Descriptions

Monitor Mode

Monitor Teacher Tape: Use the controller like a normal cassette recorder with all the usual features.

Switch the loudspeaker on/off.

Monitor Station: Allows the teacher to listen to selected student stations.

Intercom Mode

Allows the teacher to communicate with a single student station.

May be used to record on to teacher tape using headset.

Conference

Allows group communication between selected/all student stations.

In MONITOR mode, students using the CALL TEACHER button are highlighted by a flashing indicator on the LCD monitor.

In INTERCOM mode, students using the CALL TEACHER button are highlighted by a flashing indicator on the LCD monitor.

Copy Teacher Tape

Learning material can be copied from the 901 controller to student stations. If using 3902 or 3904 student stations, students can record on their track at the same time. Student stations may be individually monitored whilst recording is in operation.

Copy Line/Aux

May be used to copy material from an external CD player, radio, video (audio), etc. to all stations. If using 3902 or 3904 student stations, students can record on their track at the same time.

Copy Microphone Mode

Teacher's voice is copied on to all student stations. If using 3902 or 3904 student stations, students can record on their track at the same time.

Assessment Mode

In this mode, student responses are recorded sequentially on the student stations, for convenient assessing. Unlike the other modes, the student is recorded on the teacher track so that the cassettes can now be played back on any conventional cassette player.

Fast (x2) Copy Tape

Provides double speed cassette copy from the 901 controller to student stations (3902, 3904 or 3907).

In the COPY and ASSESSMENT modes teacher can instruct students while in 'STANDBY'.

This helps students who are waiting for teacher to begin a programme, rather than being isolated as teacher moves from one mode to another.

In the COPY, FAST COPY and ASSESSMENT modes a warning message appears on the LCD if any of the student stations present does not enter the 'RECORD' mode when 'START' is activated.

E.g. this may be because a student cassette is missing or because the cassette door is open.

WORKING IN MODES

Monitor Mode

The MONITOR Mode allows the teacher to identify and monitor individual student stations or monitor a tape playing on the Teacher Tape Deck.

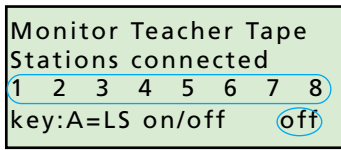

These numbers show which student stations are connected.

Indicates loudspeaker status

The loudspeaker can be switched on and off in this mode by depressing the 'A' Key.

To monitor individual students, press the appropriate student station key.

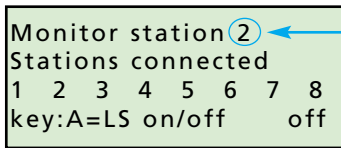

Indicates that student station 2 is being monitored.

Press the appropriate student station key again to cancel monitoring. By default, the teacher tape is then monitored.

Call Teacher!!

Students may call for attention by pressing the CALL TEACHER button on their student station.

TIP!
In MONITOR mode, the student cannot hear the teacher. To talk with the student, go to INTERCOM mode.

If the student presses their CALL TEACHER button while the 901 is in MONITOR or INTERCOM mode, the appropriate student station number flashes on the LCD display.

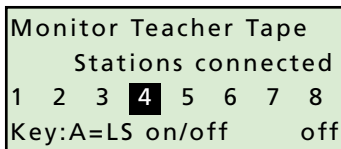

NOTE!

- A flashing block highlights the student requiring attention.
- A non-flashing block means that the student is in record.

Intercom Mode

The default setting of the INTERCOM mode allows the teacher listen to the Teacher tape and see which student stations are connected.

TIP!
While toggling between the MONITOR and INTERCOM modes, the student station settings remain the same.

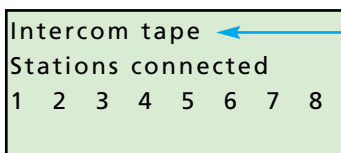

Indicates teacher tape selected

Indicates student stations connected

By pressing the appropriate station key, the teacher can communicate directly with a student or monitor student progress.

Press the same key again to cancel and return to INTERCOM TAPE, or press another station key to listen to another student.

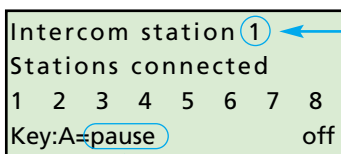

Indicates student stations selected

Indicates whether student tape is paused (off) or not (on)

Press Key A: to pause the student cassette.

Conference Mode

In CONFERENCE mode, the teacher can speak to a selection of students.

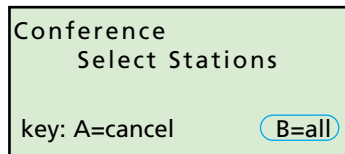

Press Key B: to select communication with all student stations instantly.

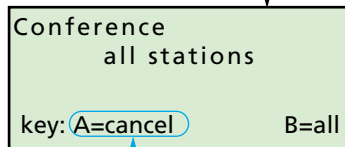

Press Key A: to cancel communication with all stations

Alternatively, the teacher may select any number of student stations to confer with one at a time by pressing the appropriate station keys.

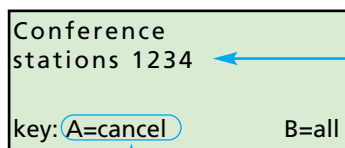

Indicates student stations selected

Press Key A: to cancel communication with selected stations

In the example above, stations 1, 2, 3 and 4 are selected.

Copy Teacher Tape

To copy programme material from a cassette tape in the Teacher Deck to the student stations.

Students can listen to the teacher tape being copied and record their responses on their track at the same time.

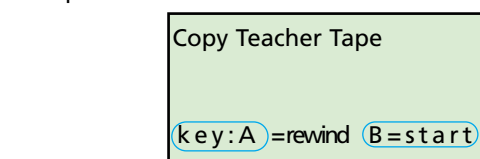

Press Key A: to rewind all student stations.
Press Key B: to start copying

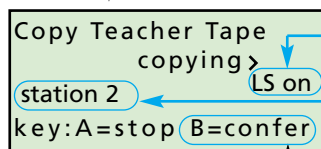
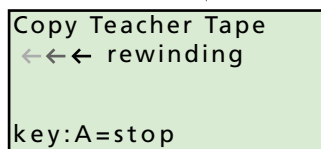

Indicates loudspeaker status

Station 2 being monitored

Press Key B to confer with all student stations.

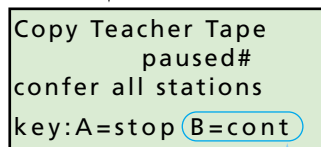

N.B. Recording pauses on all student stations until CONFER is deselected.

Press Key B to continue copying

To monitor individual students, press the appropriate student station key. Press key again to cancel monitoring or another station key to listen to a different student station.

Copy Line/Aux

The COPY LINE/AUX Mode allows the teacher to record programme material from an external source such as a CD or musical instrument to the student stations.

Note

The teacher can hear whatever is playing on the line input through the teacher headset. When recording begins, the signal can also be heard through the loudspeaker - if previously switched on in MONITOR mode.

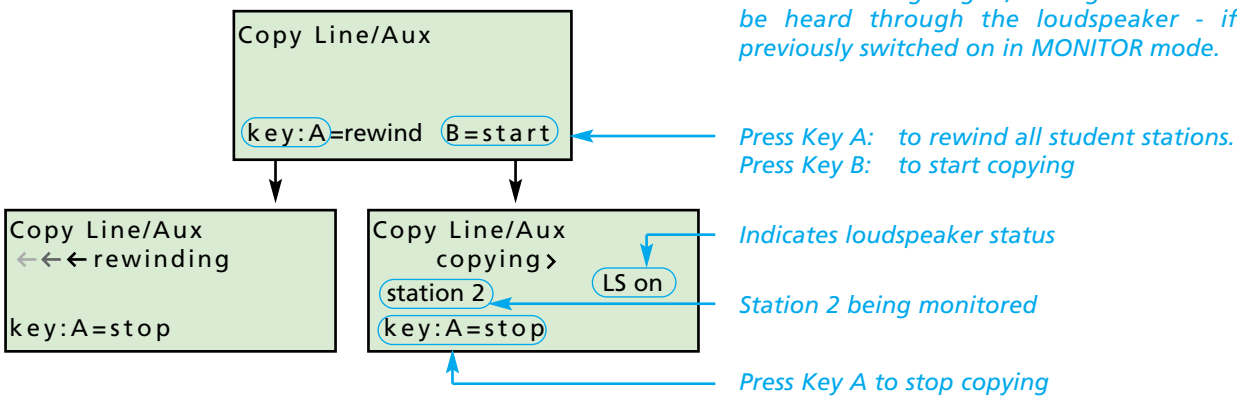

To monitor individual students, press the appropriate student station key. Press key again to cancel monitoring or another station key to listen to a different student station.

Copy Microphone Mode

The COPY MICROPHONE Mode allows the teacher to record programme material directly (live) to all student stations. At each station the student can simultaneously record a response.

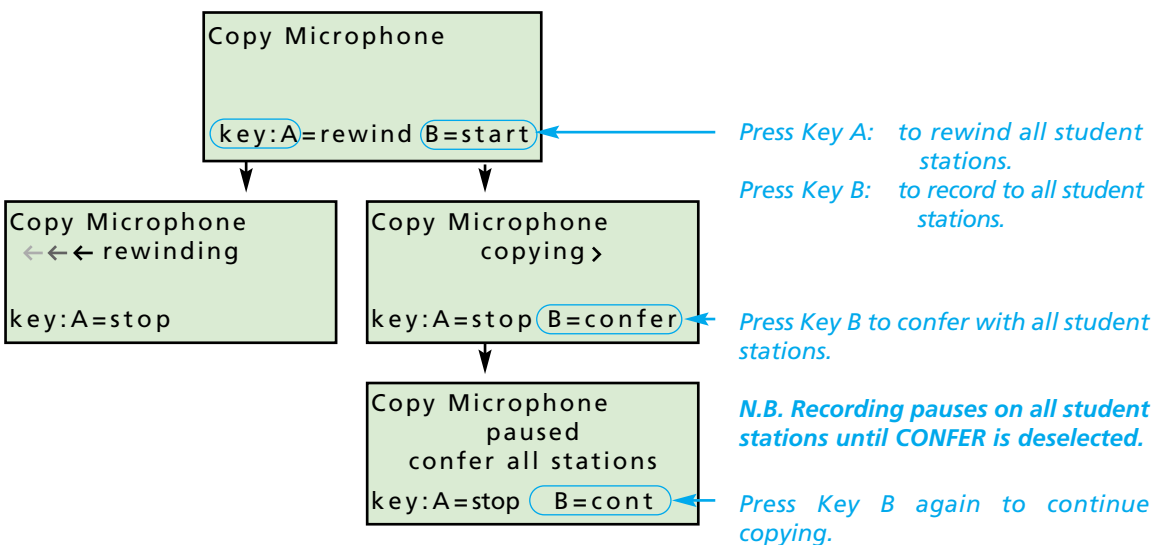

On AAC student stations, the teacher records on the teacher track while the student records responses on a separate track, the student track.

On AA student stations, students cannot record in this mode; any subsequent student recordings will erase the teacher recording.

Assessment Mode

The ASSESSMENT Mode allows the teacher to play pre-recorded tapes to all student stations and control the recording of answers by the students at their respective student stations.

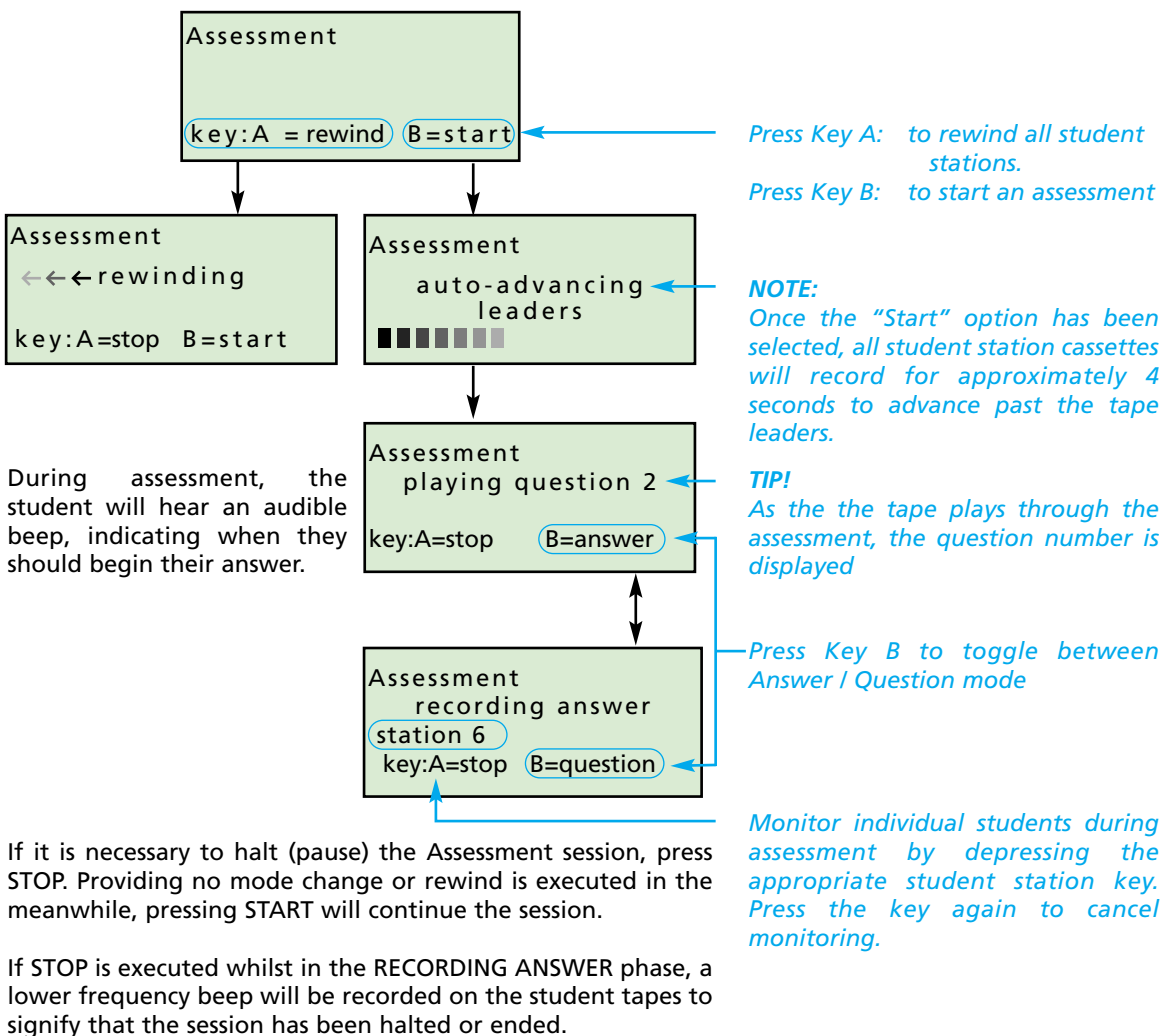

Fast (x2) Copy Tape Mode

The FAST (x2) COPY TAPE Mode allows the teacher to record from the 901 controller to all eight student stations at double speed (e.g. for the creation of assessment tapes prior to a lesson or examination).

